

Clarke®



INSTANT SHED

MODEL NO: CIS8612 (12' X 6' X 8')

PART NO: 3503580

ASSEMBLY INSTRUCTIONS

ORIGINAL INSTRUCTIONS

DL0623 - Rev 2

INTRODUCTION

Thank you for purchasing this CLARKE Instant Shed. Before attempting to use this product, please read this manual thoroughly and follow the instructions carefully. In doing so you will ensure the safety of yourself and that of others around you, and you can look forward to your purchase giving you long and satisfactory service.

GUARANTEE

This product is guaranteed against faulty manufacture for a period of 12 months from the date of purchase. Please keep your receipt which will be required as proof of purchase.

This guarantee is invalid if the product is found to have been abused or tampered with in any way, or not used for the purpose for which it was intended.

Faulty goods should be returned to their place of purchase, no product can be returned to us without prior permission.

This guarantee does not effect your statutory rights.

SAFETY WARNINGS



WARNING: READ THESE SAFETY INSTRUCTIONS TO REDUCE THE RISK OF INJURY. RETAIN THESE INSTRUCTIONS FOR FUTURE REFERENCE.

DO NOT use this product in environments for which it is not Intended (i.e. extreme cold, high winds, extreme heat, heavy rainfall, etc).

DO NOT use open flames or cooking or heating devices inside or in close proximity to the garage including all types of stoves, gas heaters, gas lanterns, torches, fly killers, etc. The fabric will burn if left in continuous contact with a naked flame.

DO NOT store flammable liquids (petrol, kerosene, propane, etc.) in the shed or operate gas powered vehicles/equipment in or around the shed.

ALWAYS follow the following instructions for anchoring the shed.

POSITIONING AND INSTALLATION OF THE SHED

POSITIONING THE SHED

This shed is a temporary structure and is not recommended as a permanent building. It is designed to offer protection from sun, rain, light snow, tree sap and bird droppings etc. It is not designed to shelter equipment from excessively high winds or heavy snow.

Choose your shed location carefully. Check for overhead power lines, tree branches, etc. **DO NOT** install near roofs or other structures that may shed snow, ice or excessive run-off onto your shed.

SITING THE SHED

The shed has internal measurements of:

- Length = 12 Feet / 3.66 Metres
- Width = 6 Feet / 1.83 Metres
- Height = 8 Feet / 2.44 Metres

Erect your shed on level ground over a firm, level area. Allow enough space near each corner for the ground anchors and tie-down straps supplied to be used as intended. If the ground area is of tarmac or concrete, the use of ground anchor holding-down bolts will be required to anchor the shed to the floor.

Choose a dry location where dampness arising from ground water in the environment will not undermine the protection offered by the shed.

A masonry floor such as block paving or concrete is ideal, but if this is not being supplied, a timber or shuttering plywood floor, protected by a suitable groundsheet should be used. This will help to create a dry storage environment by insulating the storage space from ground moisture.

Proper anchoring and keeping the cover tight and free of snow and debris is the responsibility of the user. Damage caused by improper anchoring is not covered under warranty.

CARE OF THE SHED STRUCTURE

This shed is **NOT** designed to support heavy snow. Snow or ice accumulation may cause your shed to collapse. To avoid overload, brush snow off the roof top with a broom or mop to prevent collapse with the resultant damage to property or personal injury.

NEVER clear the roof of snow or debris from inside the shed.

DO NOT use hard-edged tools or instruments, such as rakes or shovels to remove snow. These can cause punctures to the cover.

DO NOT use bleach, alkaline or harsh detergents for cleaning. Doing so will damage the material. Soap and warm water are recommended.

In order to reduce risk of burning and avoid damage, **DO NOT**- cook, smoke, refuel or use any open flame devices in or around the shed.

USING THE STORAGE SPACE

Never run the engine of any machine inside a closed shed. Ensure that there is adequate ventilation for engines or for any work with paints, cleaners. etc. by opening the door panel and keeping it raised.

























CONDENSATION

Take steps to avoid the buildup of condensation inside the shed. Cool, damp winter days and moisture from the breath and body heat of personnel may cause condensation on the inside of the top cover. A supply of fresh air through the doorway will at least partly remove this issue.

For long term storage of moisture sensitive belongings in all weathers, the use of a dehumidifier may be required, such as those in the Clarke range. A suitable extension lead to a locally available power supply will be required. Condensation will be much less of an issue during the summer months.

If storing a vehicle in your shed over the winter months we recommend the use of a secondary lightweight cover over your vehicle.

COMPONENT PARTS LIST

Part#	Description	Drawing	Qty
1	Rafter Tube		8
2	Leg Tube(Top Part)		8
3	Leg Tube (Center Bottom Part)		4
4	Roof Horizontal Tube		9
5	Bottom Cross Rail		6
6	3-Way Peak Connector		2
7	4-Way Peak Connector		2
8	4-Way Side Connector		4
9	3-Way Side Connector - Left		2
10	3-Way Side Connector - Right		2
11	Bent Corner Leg		4
12	4-Way Cross Rail Clamp		8
13	3-Way Cross Rail Clamp		8
14	Anchor		4
15	Cable (1' / 30 cm)		4
16	Cable Clamp		4
17	M6x40 Bolt		12
18	M6 Washer		12
19	M6 Nut		12+1
20	Roof Tarp		1
21	Front Door Panel (with zipper)		1
22	Back Panel		1
23	Ratchet Tie Down		8
	Owner's Manual		1

ASSEMBLY

1. Place all parts in a clear area and arrange them on the ground in front of you.
2. Remove all packaging materials and place them back in the box. Do not dispose of the packaging materials until assembly is complete.
3. Check for completeness and for any transport damage.

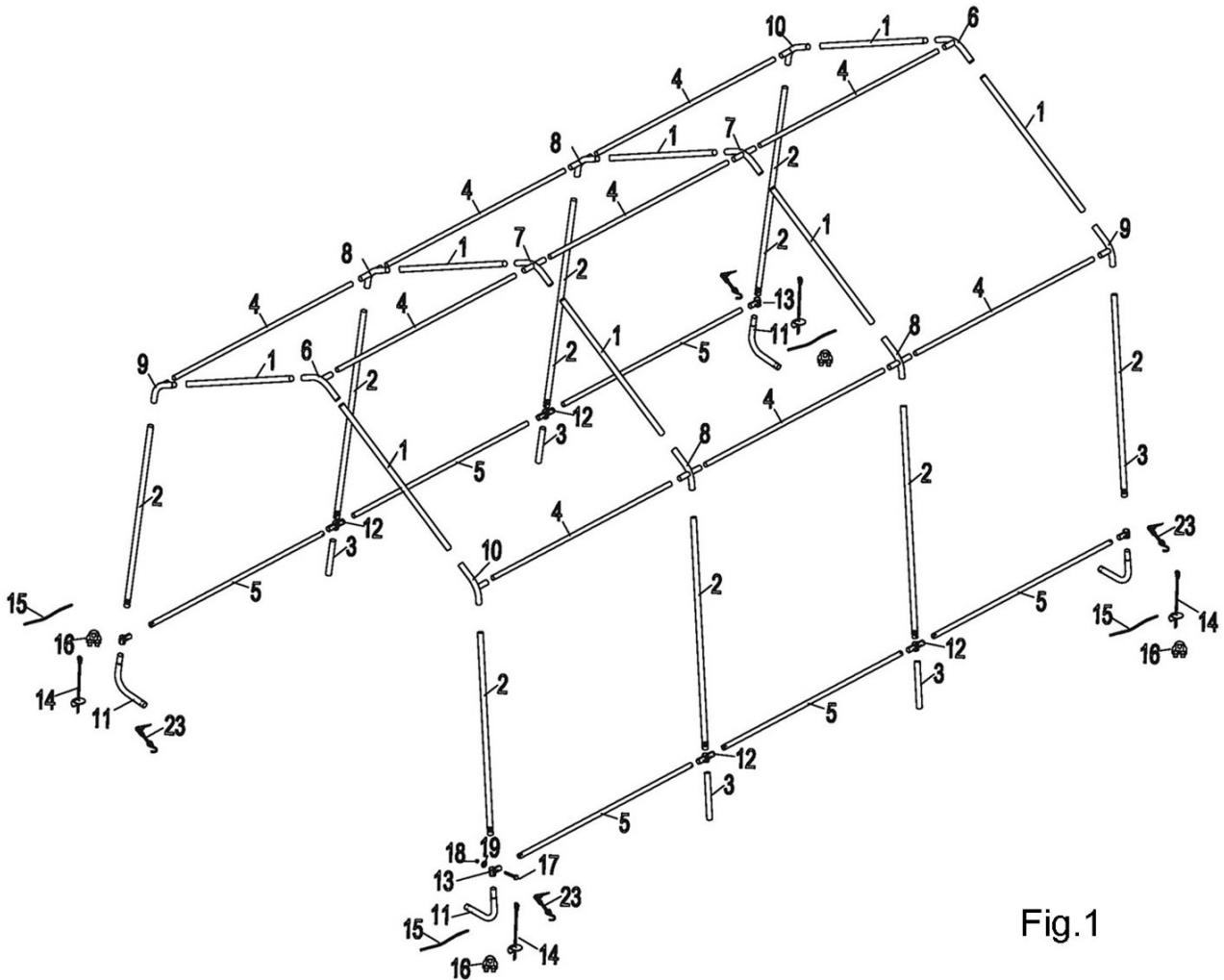

Fig.1

Tools required for assembly (not included)



STEP 1: PREPARING THE ROOF PARTS

Select a suitable location for the shed. The layout of the roof parts is shown in Fig.2.

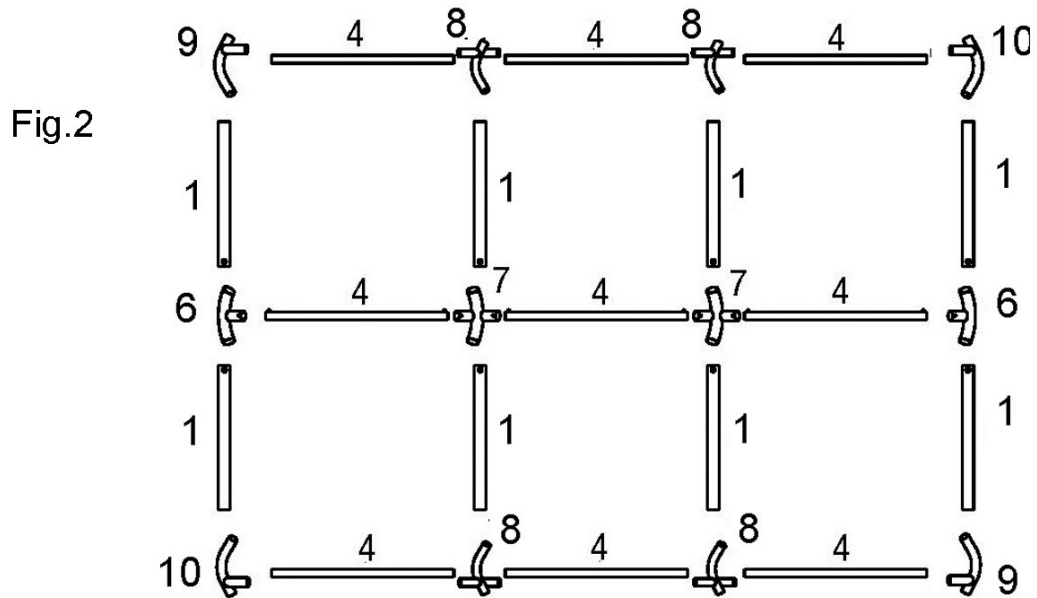

Note the differences between the connectors shown in Fig.3. (connectors are also individually numbered).

Note: When installed, the welded socket for the cross rail must be below the bend.

Parts #8, #9 & #10 are side bend connectors with a sharp bend.

Parts #6 & #7 are top apex connectors with sloping bend.

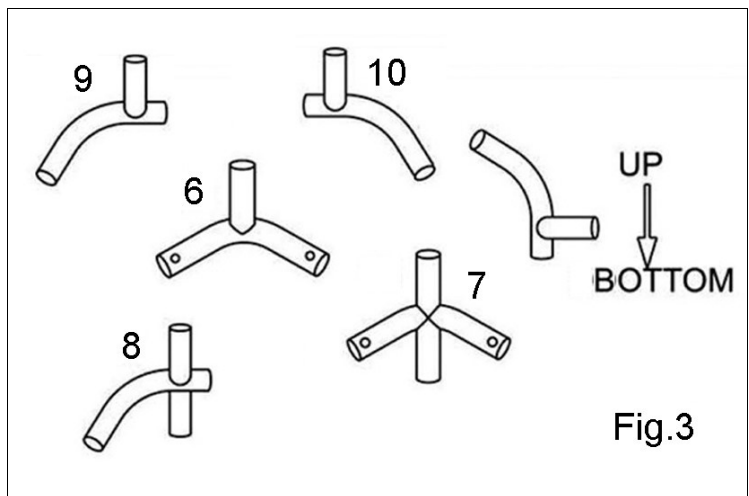
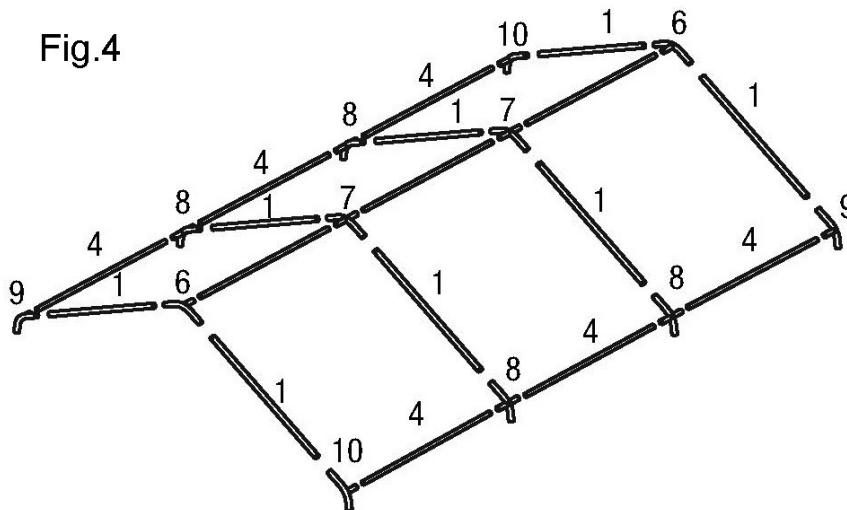

Fig.3

STEP 2: ASSEMBLING THE ROOF

Fig.4



1. Assemble the roof frame by connecting the parts layout above. Attach the roof horizontal tubes (4) and rafter tubes (1) to the 3-way connectors.
2. Use a rubber or wooden mallet to ensure all tubes are fully inserted.

STEP 3: ATTACHING THE LEGS

1. There are 8 legs for the whole shed as in Fig.5. Connect the tubes #2 & #11 to create the corner legs.
2. Connect tubes #2 & #3 to create the center legs.

Fig.5

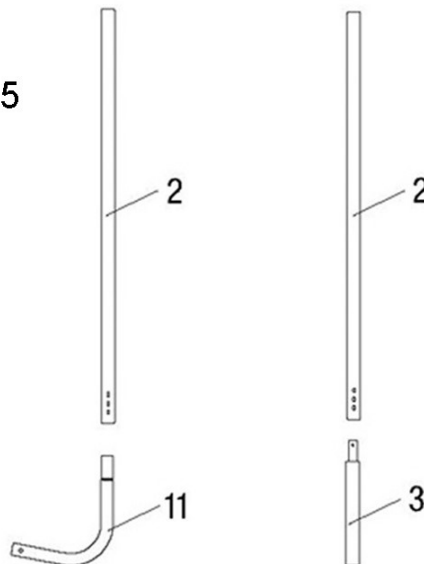

3. Insert the centre legs and corner legs into the side connectors as in Fig.6.

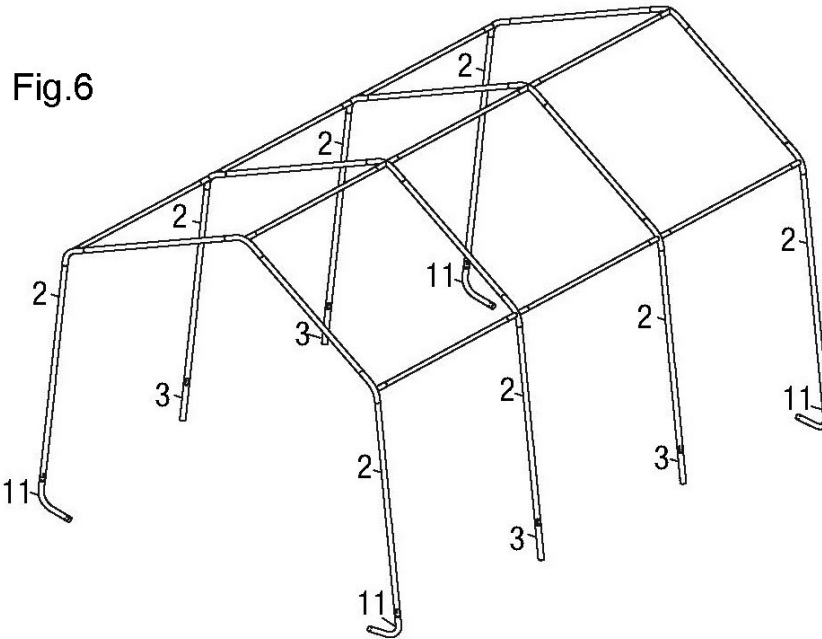

4. Repeat to assemble the other side.

STEP 5: SQUARE AND ANCHOR THE FRAME

1. Be sure that the frame is standing in its desired location.
2. Level the frame both end to end and side to side.
3. Check that the frame measures 6' wide. as in Fig 7.

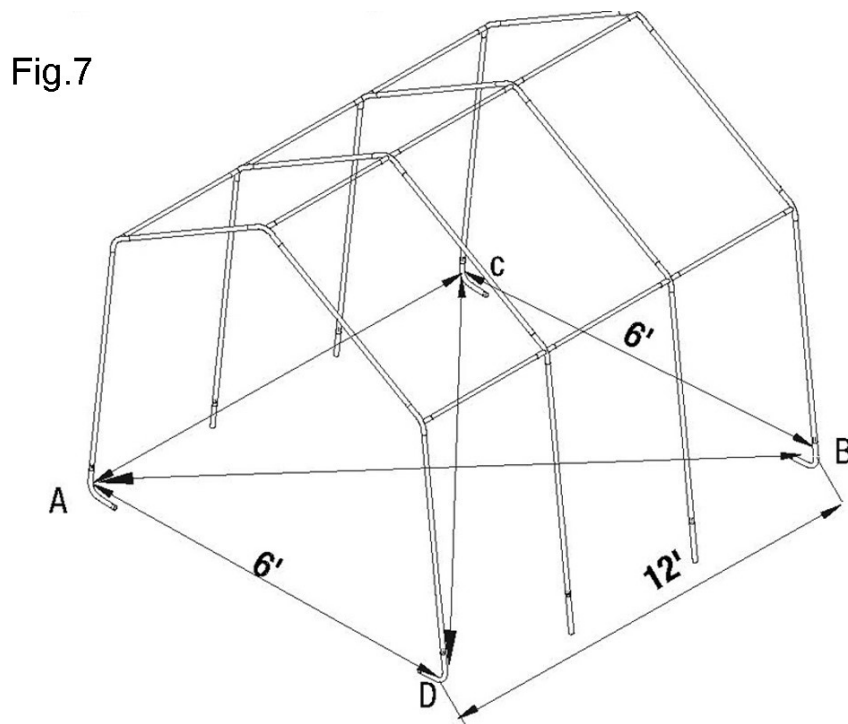

4. Take a diagonal measurement as shown in Fig.7. When these two measures are equal the frame is square. Adjust the frame until they are equal to within 1".



CAUTION: THE SHED MUST BE WELL ANCHORED. DO NOT ATTEMPT TO INSTALL ANY OF THE FABRIC BEFORE THE FRAME IS PROPERLY ANCHORED. IF THE GROUND IS HARD OR ROCKY, PRE-DRILL HOLES BEFORE INSERTING THE ANCHORS.

5. Four anchors (14) are provided to secure the structure. They are to be attached to the bent corner legs (11) at each corner of the shelter.
6. Screw the anchor (#14) into the ground on the inside of the shelter.
7. Secure with cable (#15) and cable clamp (#16) (as shown in Fig.8).

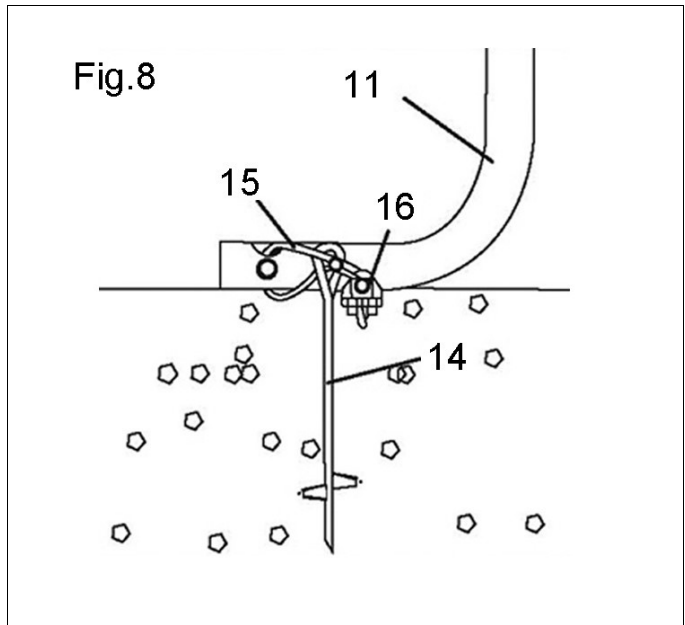

STEP 6: INSTALLING THE FRONT AND BACK PANELS

The front panel has a zippered door to allow entry to the shed. Be sure to locate this panel at the desired end and ensure the zipper is in the closed position while installing.

The back panel is a solid piece of fabric. Both the panels are installed in the same fashion.

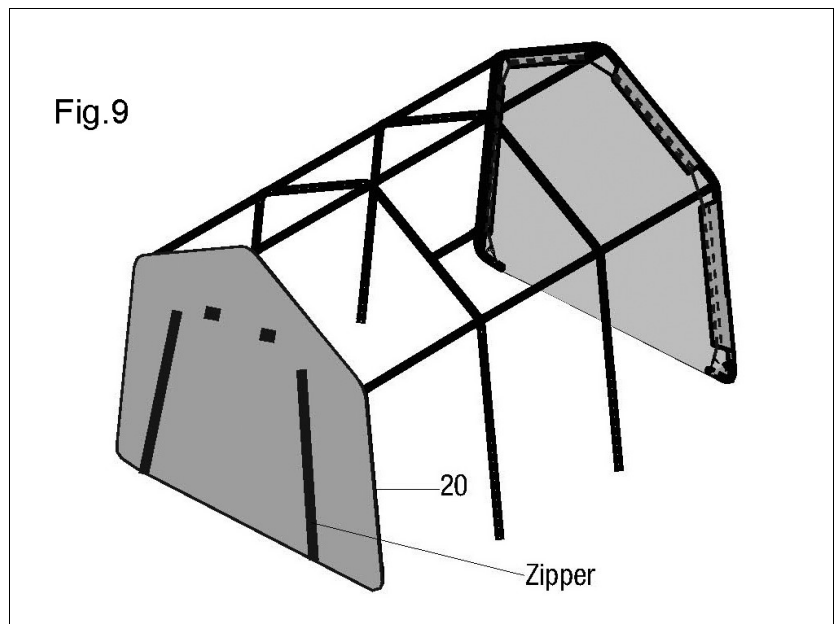

1. To make sure the strap will stay in the sleeve when assembled, thread the webbing through the spindle of the ratchet. Raise and lower the handle two or three times to wind the webbing onto the spindle as shown in Fig.10.

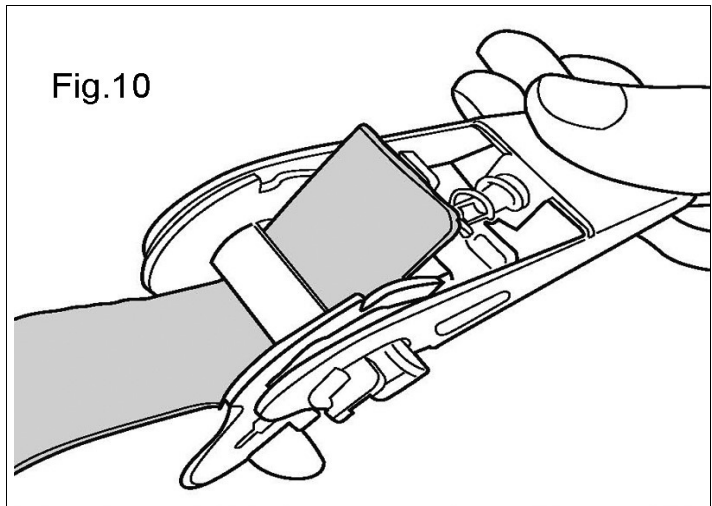

2. Raise and lower the handle a few times to wind the webbing strap onto the spindle.

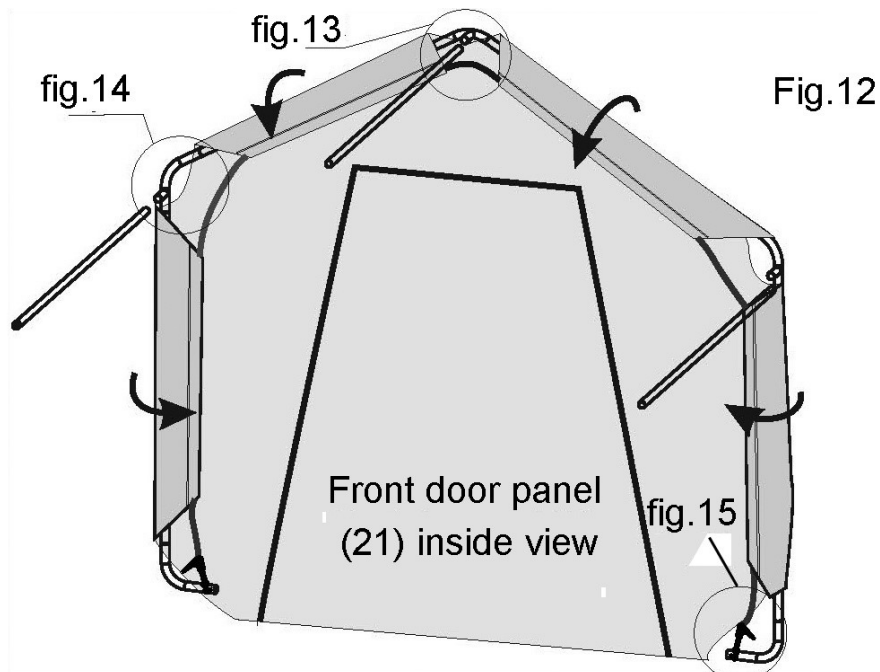
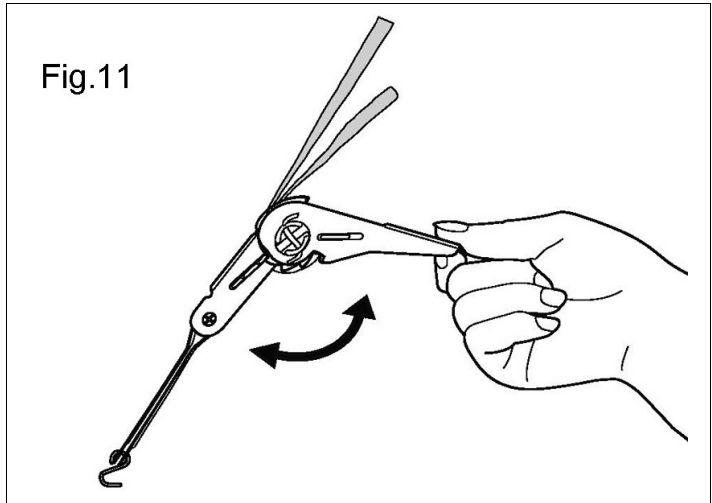

CAUTION: DO NOT THREAD THE POLES THROUGH THE SLEEVES. TO TIGHTEN, WRAP THE OUTER SLEEVES AROUND THE POLES AND TIGHTEN USING THE STRAPS PROVIDED. (Fig 12)

1. Locate the top part of the front door panel (21) near the 3-way peak connector (6) Disconnect the shoulder cross rail (4) from the 3-way peak connector (6) and pull the strap onto the connector. Then re-insert the cross rail to its proper position. as in Fig 13.

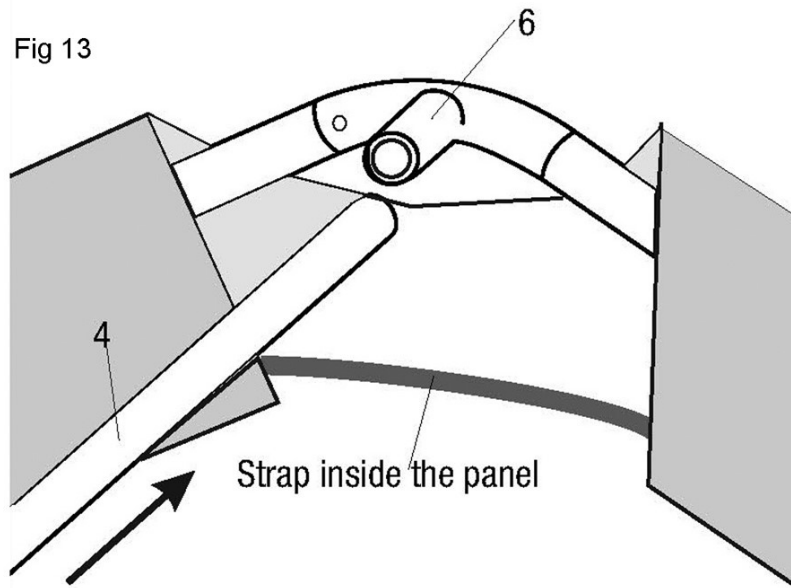

2. Attach the other two corners of the front door panel (21) to the 3-way side connectors (9, 10) in the same way. as in Fig 14.

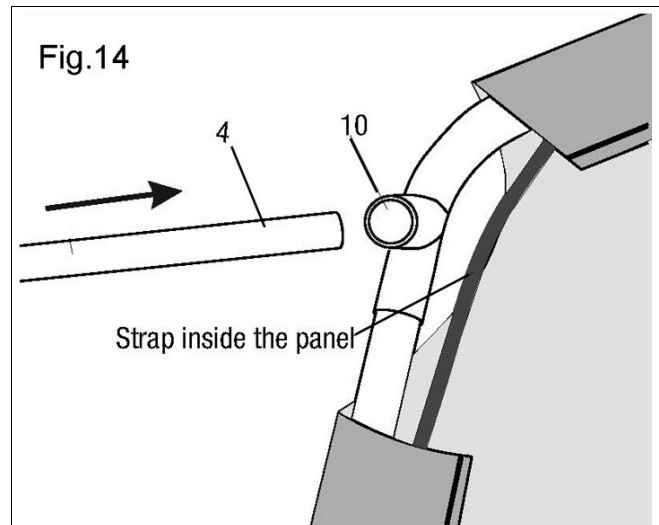

3. Insert the S-hook of the ratchet into the hole of the bent corner leg. Pump the ratchet repeatedly to tighten the strap.

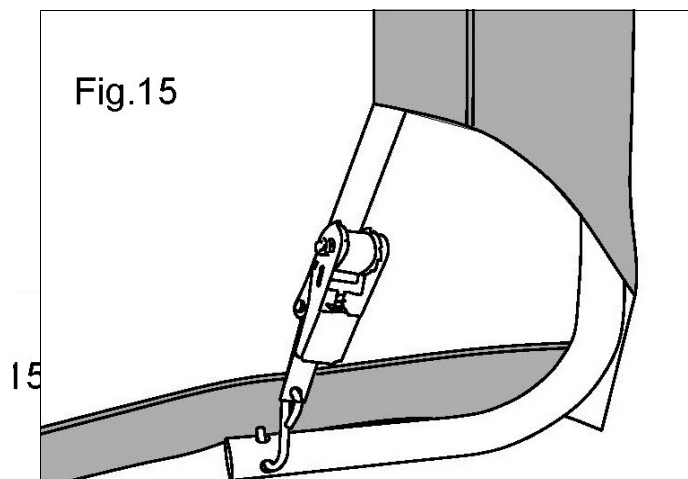

STEP 8: INSTALLING THE MAIN COVER

1. Lay the main cover on the ground next to the frame. Make sure the corners with the black straps are alongside the front & back panels and the tube sleeves are facing upwards.

2. Tie a rope to the eyelets on the cover, one each side. Pull the cover over the frame using the rope as shown, making sure to centre the cover on the frame. There should be an equal overhang on each corner. Use a ladder if necessary.

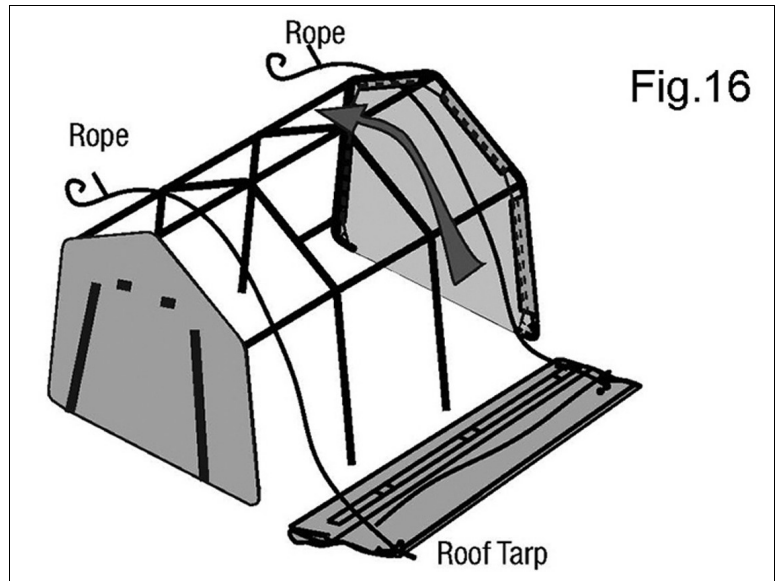

3. If small adjustments are needed, two people should pull the roof cover from the same side so that it does not twist.

4. Slide the cross bottom rails through the tube sleeves on one side of the roof cover.

5. Assemble the clamps and fitting and tighten slightly.

6. Make sure the cross rails are level and horizontal.

7. Repeat the same procedure for the opposite side of the cover.

8. Check and make sure all the bottom cross rails are level and are the same distance from the ground.

9. Tighten all nuts and bolts at this stage.

10. Fasten the black straps at each corner with the ratchet tie-down,

NOTE: Over-tightening can cause damage to straps and/or the anchor point. Do not over-tighten.

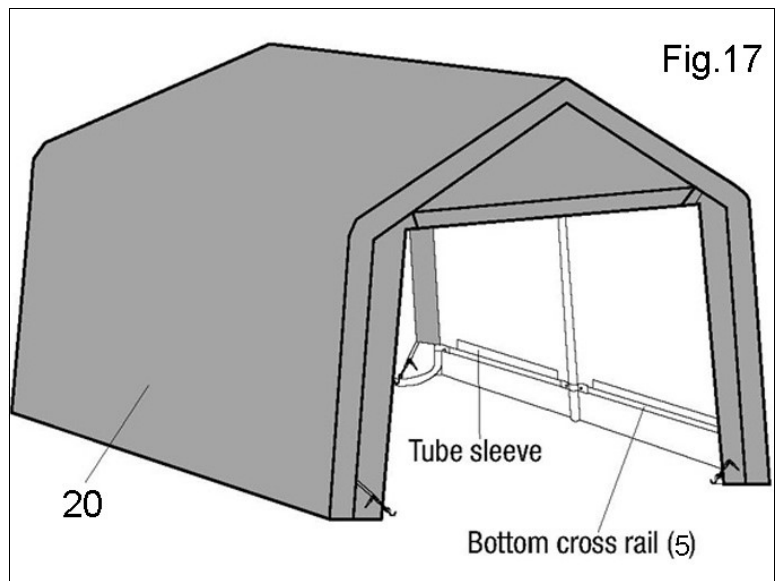

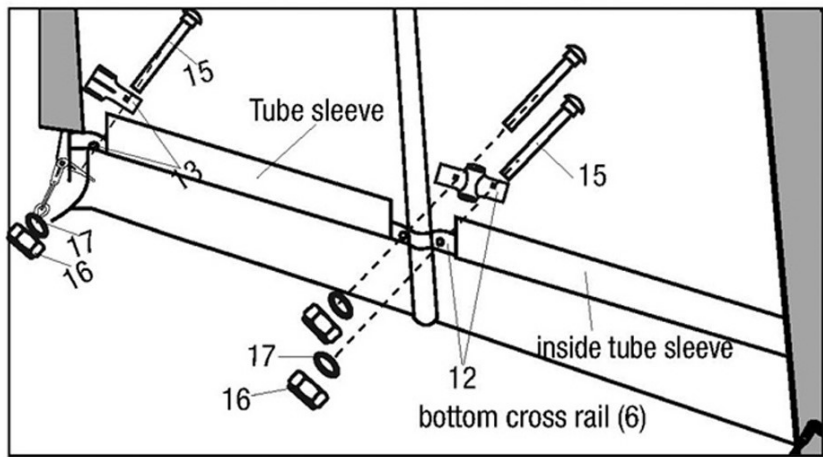
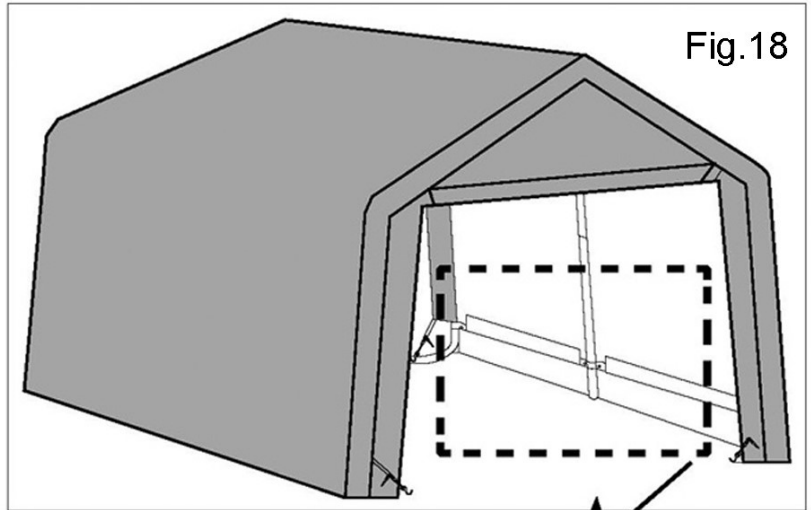

The shed is now ready for use.

Check periodically and tighten ratchet tie-downs and all hardware as needed. Routine inspection is recommended throughout usage.

DISASSEMBLY

When disassembling the shed depress the spring-loaded bar to disengage the ratchet and open the ratchet handle completely to allow the webbing strap to pull through.

PLEASE RE-READ ALL WARNINGS CONTAINED ON PAGE 2 OF THESE INSTRUCTIONS. SAVE THESE INSTRUCTIONS FOR FUTURE USE.

To dismantle, execute all instructions in reverse order.

Store your shed in a cool, dry location between seasons to prolong the usable life of all components.

Components are not equally durable and will require replacement over time at differing intervals.

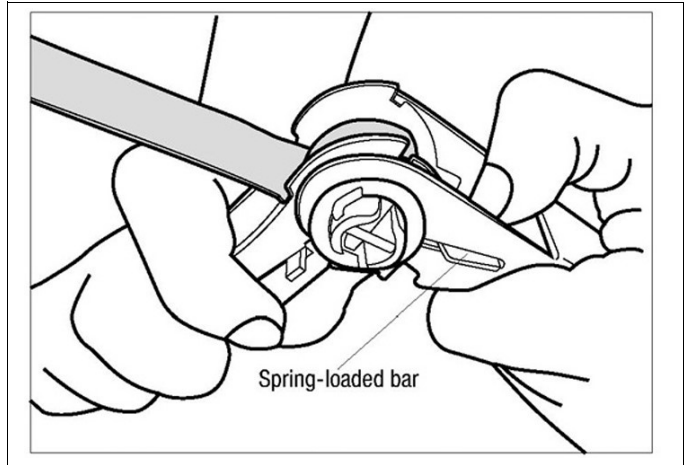

ADDITIONAL ANCHORING

Please note that when the instant shed is to be sited on soft ground an additional, or alternative method of anchoring may be required.

This can take the form of an additional Auger Securing Set (Part No: 3503586), which can add greater security for exposed, windy locations.

Alternatively the Easy Hook Anchoring System GHA2 (Part No: 3503588), can be used to provide greater security on soft ground.



Available from your Clarke dealer.

A SELECTION FROM THE VAST RANGE OF

Clarke®

QUALITY PRODUCTS



AIR COMPRESSORS
From DIY to industrial, Plus air tools, spray guns and accessories.

GENERATORS
Prime duty or emergency standby for business, home and leisure.

POWER WASHERS
Hot and cold, electric and engine driven - we have what you need

WELDERS
Mig, Arc, Tig and Spot. From DIY to auto/industrial.

METALWORKING
Drills, grinders and saws for DIY and professional use.

WOODWORKING
Saws, sanders, lathes, mortisers and dust extraction.

HYDRAULICS
Cranes, body repair kits, transmission jacks for all types of workshop use.

WATER PUMPS
Submersible, electric and engine driven for DIY, agriculture and industry.

POWERTOOLS
Angle grinders, cordless drill sets, saws and sanders.

STARTERS/CHARGERS
All sizes for car and commercial use.



PARTS & SERVICE: 0208 988 7400

Parts Enquiries
Parts@clarkeinternational.com

Servicing & Technical Enquiries
Service@clarkeinternational.com

SALES: UK 01992 565333 or Export 00 44 (0)1992 565335

Clarke® INTERNATIONAL Hemnall Street, Epping, Essex CM16 4LG
www.clarkeinternational.com